

Trilogy Series Note Acceptors are competitively priced and designed for indoor use in the amusement, gaming, vending, lottery and kiosk markets.

Based on the model, the Trilogy Acceptors can accept notes from 60mm to 85mm in width. Trilogy Series are compatible with most popular Note Acceptors.



Trilogy Acceptor Features

- Dual-stage optical anti-stringing
- Acceptance rate 95% or greater
- Low cost
- Simple configuration and setup with configuration card or PC
- Lighted arrows on bezel
- High security against fraudulent notes
- Optical, anti-stringing design
- Flash downloadable software using a PC (Currency updates are free of charge)
- On-board pushbutton/LED and advanced diagnostic via PC
- Many interfaces available: Pin-outs compatible with other manufacturers' note acceptors
- 12 VDC (+/- 10%) operation
- Removable note path for easy cleaning and maintenance

Serial Communication Options

- ccTalk, parallel binary (standard), 600 baud serial and USB versions available (optional)

Part no.	Description
T51N2EUR104	Trilogy Euro Bill Acceptor

SPECIFICATIONS

Product Specifications

Operating Voltage:	12 VDC (+/- 10%) standard
Operating Currents:	Idle: 50mA Accepting: 1.0 A Stalled: 3.0 A
Operating Temperature:	0C - 60C, 90% non-condensing humidity
Acceptance Rate:	Greater than 95%, including second time insertion of a rejected note
Acceptance Speed:	Approx. 20 notes per minute
Sensor Array:	10 Optical Sensors
Notes Accepted:	Up to 12 notes in all four directions. (Up to approx. 48 faces)
Net Weight:	Stackered Model (in preparation).....2.3 lbs./1.04 kg Starkerless Model..... 1.3 lbs./0.59 kg
Warranty:	2 years, parts and labor (see Warranty Section)

EURO-STYLE BEZEL

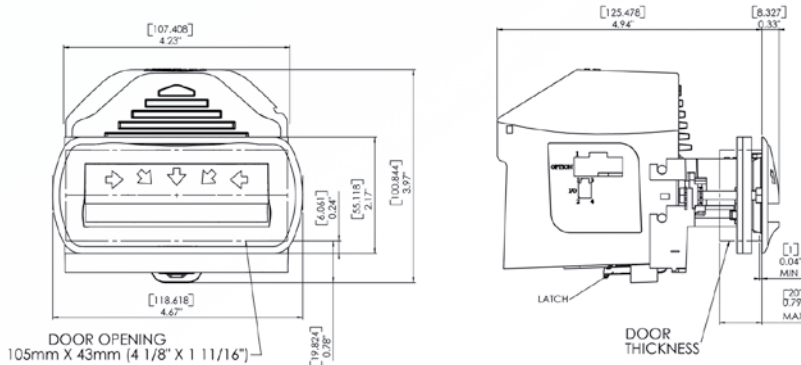

USA-STYLE BEZEL

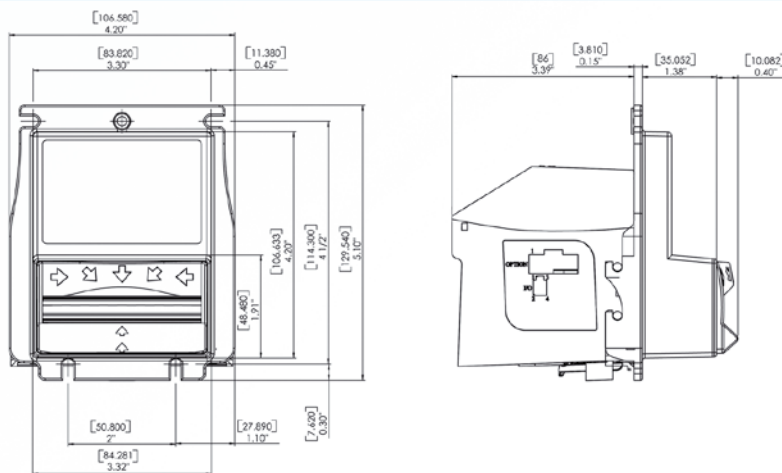

Bezels



Euro-Style Bezel

Notes up to 85mm in width



USA-Style Bezel

Notes up to 74mm in width

SUZO®

THE NETHERLANDS

SUZO INTERNATIONAL (NL) BV
Antonie van Leeuwenhoekstraat 9
3261 LT Oud-Beijerland
Tel: (+31) 186 64 33 33
Fax: (+31) 186 64 33 22
E-mail: sales@suzo.com
Website: www.suzo.com

GERMANY

SUZO INTERNATIONAL (D) GMBH
Aachener Strasse 122
D 52477 Alsdorf-Hoengen - Germany
Tel: (+49) 2404 98 680
Fax: (+49) 2404 98 68 68
E-mail: sales@suzo.de
Website: www.suzo.com

BELGIUM

SUZO INTERNATIONAL (B) BVBA
De Vletlaan 52
B 2920 Kalmthout - Belgium
Tel: (+32) 3 6770745
Fax: (+32) 3 6770746
E-mail: suzobelgie@skynet.be
Website: www.suzo.com

POLAND

SUZO POLSKA Sp.z.o
Ul. Wierzbowa 109, Wysogotowo k/Poznania
62-081 Przemierowo
Tel: (+48) 61 8162 010
Fax: (+48) 61 8141 132
E-mail: info@suzo.pl
Website: www.suzo.pl

ARGENTINA

SUZO AMERICAS (AR) A.R.L.
Tte. Cnel. Besares 4693
(C1430CII) - Buenos Aires - Rep. Argentina
Tel/Fax: (+54) 11-4546-0588
E-mail: info@suzo-americas.com
Website: www.suzo-americas.com

BRASIL

STC COMPONENTES DO BRASIL Ltda.
Av. Santos Dumont 6760
89226-470 Joinville - SC - Brasil
Tel/Fax: (+55) 47-4674871
E-mail: info@stccomponentes.com.br
Website: www.suzo.com

SPAIN

STC España
C. Manuel de Falla, 12, 2A Planta
Oficina 8
E 28100 - Alcobendas / Madrid
Tel: (+34) 916546203
Fax: (+34) 916513974



TRILOGY

PYRAMID TECHNOLOGIES, INC.

Suzo is a trademark of Suzo International (NL) BV. Information is subject to change without notice. Suzo has made every effort to ensure that the information in this document is accurate. However, we cannot be held responsible for any errors or omissions.



GAMING, AMUSEMENT & INDUSTRIAL COMPONENTS